

VARSI-A HF50 HYDRO FOAM NOZZLE

TECHNICAL DATA :

NOZZLE FLOW RANGE	3030 TO 4750 LPM (800 TO 1250 GPM)
WATER INLET CONNECTION	Swivel female 4" BSP
FOAM CONCENTRATE INLET CONNECTION	Female 1.25" BSP (Camlock optional)
PICK UP TUBE	3.0 mtrs. long clear PVC with SS dip tube.
MATERIAL OF CONSTRUCTION	Hard Anodized Aluminium (Optional - Bronze)
MAXIMUM WORKING PRESSURE	12 Bar (175 PSI)
JET & FOG PATTERN	With Spining teething
WEIGHT	Aluminium material - 9.5 Kg Bronze material - 21.5 Kg

APPLICATION

VARSHA HF50 – Hydro Foam Nozzles have been designed for wide flow range from 3030 to 4750 LPM (800 to 1250 US GPM) for use with Monitors.

These are fixed flow nozzles, simple and rugged with superior stream and reach. The straight stream from maximum reach can be easily changed to wide fog pattern under flow condition by rotation of the pattern adjustment sleeve. The nozzle is provided with spinning teeth.

The nozzle is made out of hard coat anodized aluminium. The VARSHA HF50 is a self inducting nozzle equipped with a foam concentrate pick up tube of 3.0 meters long with a swivel connection or optional camlock coupling for quick connection.

The nozzle can be used as a water nozzle and when foam supply is established, it acts as a self inducting Foam Nozzle. The performance data shows effective stream trajectory in stand still air condition. The maximum overall reach of last drop is approximately 3-5% more than the effective stream performance data. The jet stream may get effected considerably with tail or head wind.

The debris trapped in the nozzle may effect the nozzle performance. To remove trapped debris, the water flow must be stopped and thereafter carefully unscrew and remove the nozzle deflector. Clean the nozzle and reassemble. While reassembling the nozzle or as a normal preventive maintenance, water proof lubricant must be used on seal and moving parts for smooth operation. The nozzle must be operated periodically under full flow jet as well as under fog pattern.



CAUTION

A trained personnel for fire fighting, with appropriate guidance and training must use the product to reduce the risk or injury. The nozzle must be fixed to the monitor carefully. The mismatched or damaged threads may cause leakage or uncouple the nozzle under operation.

Application of water or foam on an electric appliance can cause serious injury by electrocution, as water is a conductor of electricity.

The water supply to the nozzle must be gradual. Sudden surge of water supply must be avoided. The monitor mounting must be supported properly to support the nozzle reaction force.

MAINTENANCE:

The nozzle must be inspected regularly for possible damage or dirt around the moving parts. If any abnormal conditions observed such as poor discharge, excessive wear, water leak, corrosion effect, damage etc., then nozzle must be taken out of service and repaired by qualified technician.

Under normal condition water must be flown through the nozzle periodically and dirt from around exterior moving parts must be cleaned, allowing nozzle to operate properly.

The nozzle must be inspected prior to and after each use. Greasing the moving parts and 'O' ring is required periodically. Over a time the seals may need to be replaced.

The owner is responsible for maintenance of the nozzle in proper operating condition.

After use with foam, flush with fresh water.

VARSIA HF50 HYDRO FOAM NOZZLE

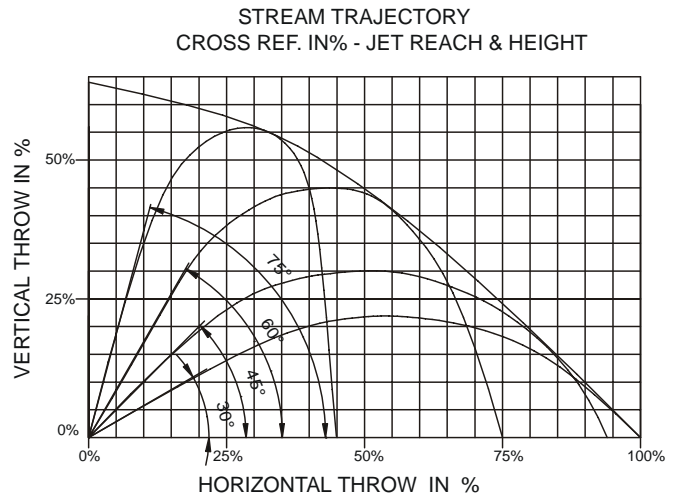
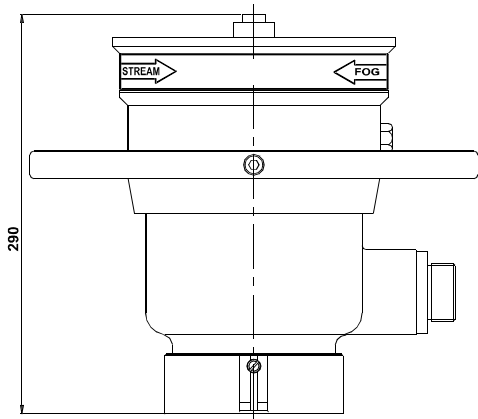

PERFORMANCE DATA

SET FLOW RATE LPM (GPM)	FOAM CONCENTRATE INDUCTION RATE	NOZZLE PRESSURE KG/CM. SQ. (PSI)	ACTUAL FLOW RATE LPM (GPM)	STRAIGHT STREAM FOAM RANGE METERS (FEET)
3030 (800)	3% OR 6%	5.6 (80)	2700 (715)	51 (167)
		7.0 (100)	3030 (800)	58.0 (190)
		8.4 (120)	3315 (876)	59.5 (195)
3800 (1000)	3% OR 6%	5.6 (80)	3400 (898)	53 (173.5)
		7.0 (100)	3800 (1000)	60.0 (196.5)
		8.4 (120)	4165 (1100)	61.5 (201.5)
4750 (1250)	3 %	5.6 (80)	4250 (1125)	53 (173.5)
		7.0 (100)	4750 (1250)	61.0 (200)
		8.4 (120)	5200 (1375)	63.0 (206.5)

PERFORMANCE DATA FOR FOAM STREAM RANGE ARE BASED AT 30 DEG. NOZZLE ELEVATION IN STILL AIR CONDITION AND WITH MONITOR. THE REACH IS FOR FOAM, WHEN USED AS WATER THE WATER REACH WILL INCREASE BY ABOUT 10%.